



## Upright Fridge and Freezer range

Ever thought it would make sense if the people who spend their time fixing things were involved in making them? They would probably design equipment that worked better for longer.

That is what we thought so we teamed up with an innovative European manufacturer and used our knowledge, gained through a lifetime of resolving equipment breakdowns, to build the most reliable range of commercial refrigeration equipment we think you are likely to find.

# AXIS

Catering equipment with **reliability** built in

## AXIS MODELS R700D/F700D/R1400D/F1400D

We believe our refrigeration range is unsurpassed. We use the highest grade materials, the best components and precise engineering skills to make our equipment right for you. But do not take our word for it, look at the list of features, make your own comparisons and draw your own conclusions.

### Features:

- Manufactured in Europe with care and attention to detail
- Made from AISI 304 18/8 stainless steel, exterior and interior
- Insulated with ecological polyurethane
- Includes LED panel to clearly display temperature
- Designed to operate up to 46°C ambient temperature
- Uses environmentally-friendly refrigerants
- Auto defrost
- Meat-safe
- Gastronorm-sized
- Supplied with 3 generous interior shelves (per door) as standard
- Fitted with heavy duty lockable swivel castors for easy manoeuvrability
- Self-closing doors
- Removable magnetic door gasket
- Removable racking with anti-tilt slides
- Easy clean interior

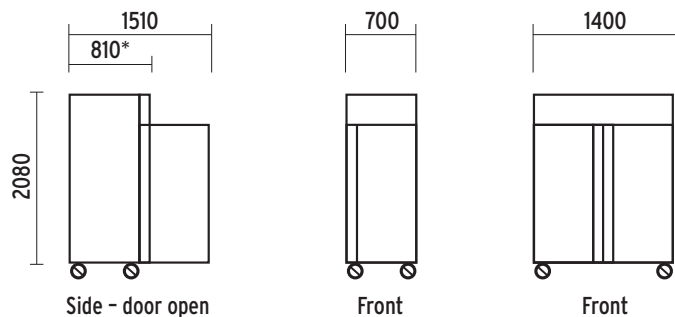

\*All models are 810mm deep

Description:	Single Door Upright		Double Door Upright	
	Fridge	Freezer	Fridge	Freezer
Type:	Fridge	Freezer	Fridge	Freezer
Model No:	R700D	F700D	R1400D	F1400D
AISI 304 18/8 Stainless Steel exterior and interior	✓	✓	✓	✓
Zero ODP injected polyurethane insulation (50mm)	✓	✓	✓	✓
46°C high ambient top mounted refrigeration system	✓	✓	✓	✓
Electronic controller with alarms	✓	✓	✓	✓
Electronic hot gas defrost (M & L)	✓	✓	✓	✓
Automatic off cycle defrost (H)	✓	✓	✓	✓
Removable racking with anti-tilt slides	✓	✓	✓	✓
2/1 Gastronorm shelving system	✓	✓	✓	✓
Number of interior shelves as standard	3	3	6 (3 per door)	6 (3 per door)
Single door units hinged on the right as standard and can be reversed if required	✓	✓	Not applicable	Not applicable

# AXIS

Catering equipment with **reliability** built in